

VOLTECHNOTES

Using the AT Series User Port



VoltechTM

AT SERIES USER PORT OPERATION

Relay Drive Output Operation

Both the Voltech AT3600 and ATi transformer tester possess a user port connector (9-way, 'D' type, female). This connector has been designed to facilitate an open-collector relay drive output. The relay drive output is provided in a unique test called "OUT". Six relay drive outputs are available to the user and can be pre-programmed via the Voltech AT Editor software to output to a number of sources or applications. Figure 1 below shows the pin-outs available for the six relay drives:

Pin	Signal name
1	O/P user relay drive 0
2	O/P user relay drive 2
3	O/P user relay drive 4
4	I/P user input 0
5	+12V DC @ 1A
6	O/P user relay drive 1
7	O/P user relay drive 3
8	O/P user relay drive 5
9	I/P user input 1

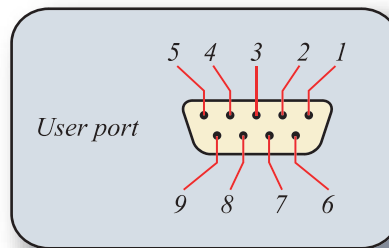

Figure 1

Each relay output can drive a load of $>150\Omega$ and has a maximum current output of 80mA.

The AT3600 user port is accessible at the top rear of the product.



The AT3600 allows easy access to its user port. Relays and additional components (LEDs, etc.) can be assembled directly onto the test fixture with its control lead plugged into the 9-way, D user port.

The ATi user port is located on the rear panel of the unit, next to the earth socket.



The ATi also allows easy access to its user port and can accommodate relays and additional components on the test fixture itself.

Note

An “OFF” state for the relay drive outputs is the default setting when the AT is switched on. However, after each programmed "OUT" test, the relay drives will remain in the programmed condition until another "OUT" test is run, or the AT is switched off and on again. During subsequent "OUT" tests, the AT, firstly, identifies relays that are programmed to be “OFF” and releases those relays first. Secondly, the AT identifies relays that are programmed to be “ON” and energizes those next. The relay switching “OFF” time is almost instantaneous. Switching “ON” times, however, are around 20mS.

Relay Drive Applications

Component Adding

The most common use of the "OUT" test is to close a relay in order to introduce an additional component to the test circuit, such as a resistor, as shown in Figure 2 below.

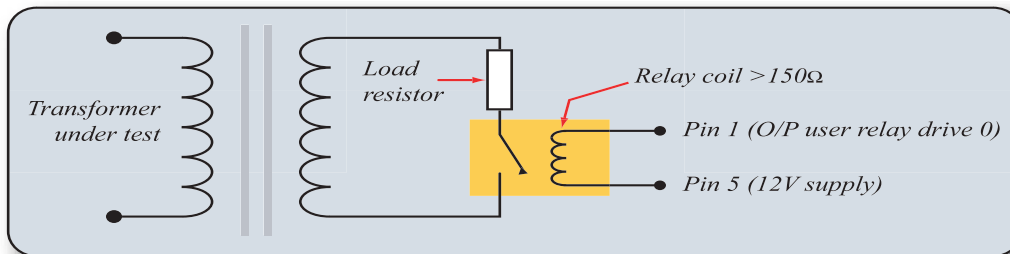

Figure 2

Figure 3 (right) shows a block diagram of the relay output, which is internal to the AT.

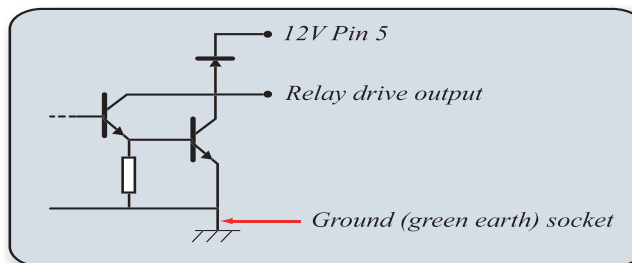

Figure 3

Component Adding Applications

- The most common tests where the introduction of a component is required are to measure impedance mismatch between the transformer and the transmission line. The component, in those cases, would be a resistor for tests such as GBAL (General Longitudinal Balance), LBAL (Longitudinal Balance), ILOS (Insertion Loss) and RLOS (Return Loss).
- Discharging the circuit may be required where testing involves passive components such as capacitors. These may require discharging prior to operator removal of the part under test.

Triggering for An External Device

During a test sequence, an external device may require triggering. This could be either through a relay or direct to an “ENABLE” input by using a pull-up resistor (Figure 4).

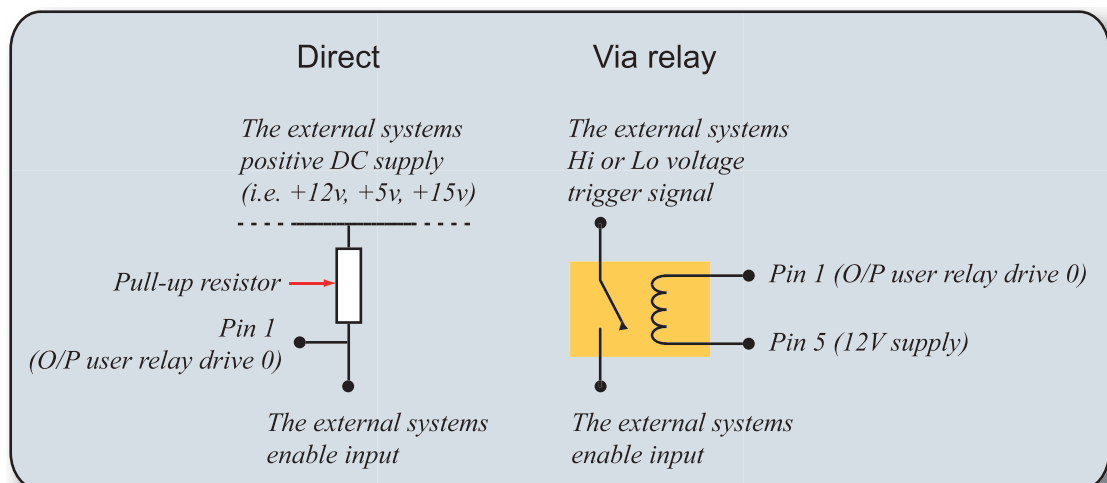

Figure 4

External Device Trigger Applications

- Batch counting. The trigger is sent to a digital or electrical counter in order to count the entire batch being tested.
- Conveyor belt. The trigger is sent to a timer that operates a conveyor belt, which moves passed parts along a production line.
- Robotic arm. The trigger is sent to a PC that controls a robotic arm that removes tested parts and/or places parts that are ready for test.

Test Cycle Indication

During a test sequence, an LED indicator (and/or buzzer) can be used as an indication of a certain point within the program cycle being reached (Figure 5).

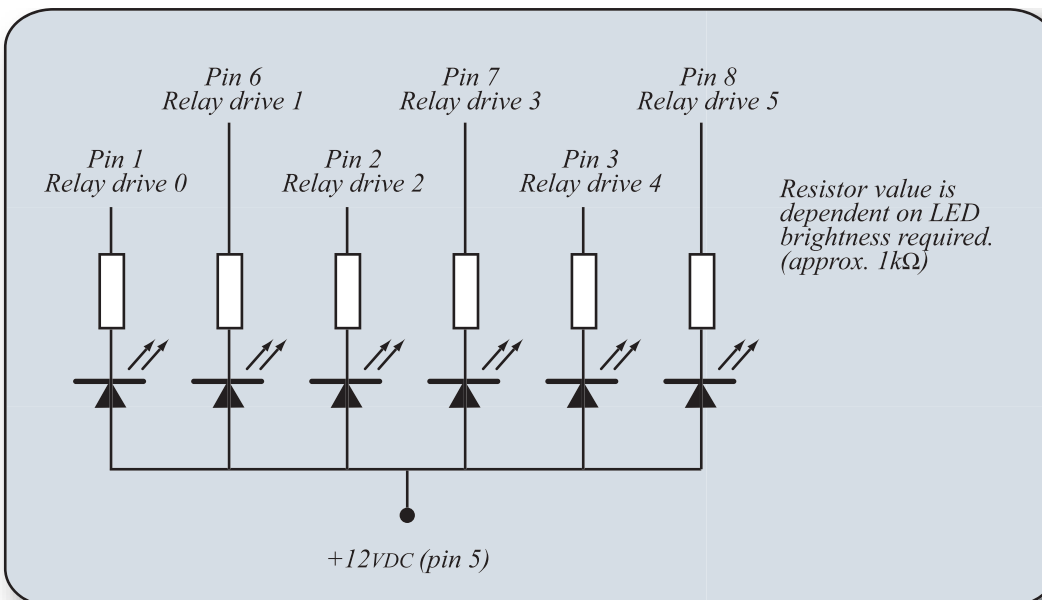

Figure 5

Test Cycle Indication Applications

- A timed buzzer or illuminated LED to warn the operator that the part is undergoing a hi-pot or high-voltage test.
- During multiple part testing (maximum of six - one LED per part tested), an LED can be arranged to show the test status of a particular part under test (i.e., LED illuminates when part is tested).

Relay Drive Set-up

The "OUT" test is accessed via the AT Editor software and can be placed anywhere in a program cycle (Figure 6).

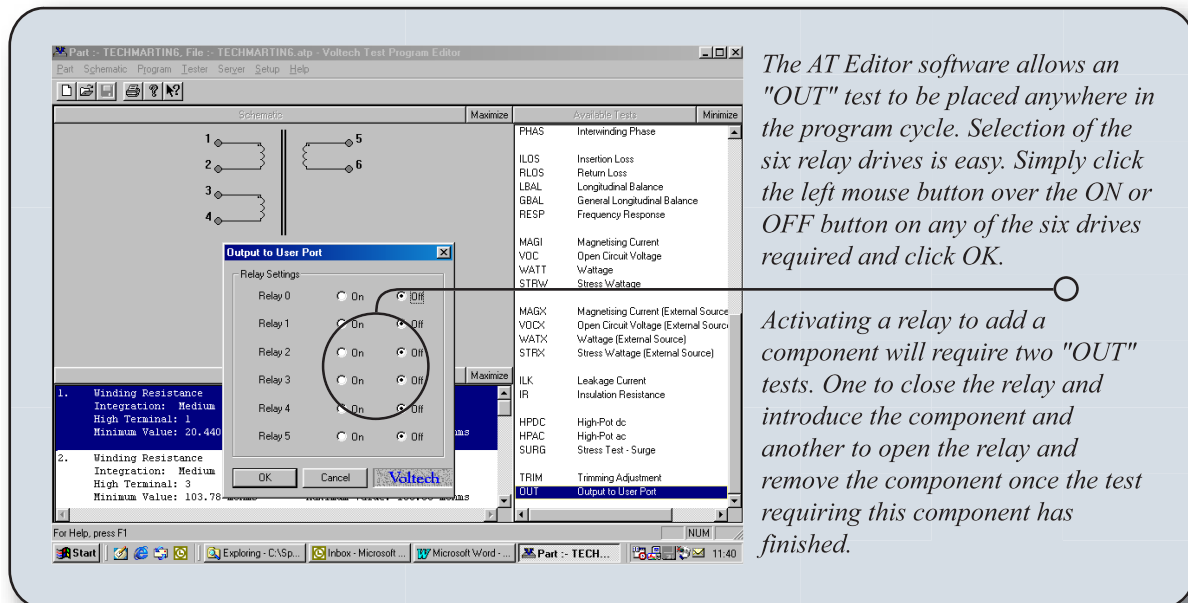

Figure 6

Activating an enable output (and/or a program cycle indicator) would require the "OUT" test set-up in the appropriate area of the program in order to output the required event.

Typical Relay Specification And Recommended Cables

The list below shows the typical specification required when using relays in circuit. However, providing that a coil rating of $>150\Omega$ is used at 12VDC, other relays (meeting the typical specification) can be used.

Typical Relay Specification:

- Switching current: 2A maximum
- Coil resistance: $290\Omega \pm 10\%$
- Reed switch isolation: 10KVDC
- Coil-to-contact isolation: 10KVDC
- Coil voltage: 12VDC
- Contact resistance: $<50m\Omega$
- Voltech part number: 33-004

Recommended Cable:

- Sub-miniature, screened 7/0.1 multi-core with minimum of seven cores (Farnell part number: 711-380)



*The Voltech AT3600 and ATi
Automatic Transformer Testers*

VOLTECHNOTES

Voltech Instruments Ltd.

148 Sixth Street
Harwell International Business Centre
Harwell, Didcot, Oxon OX11 0RA
United Kingdom
Telephone: **+44 (0)1235 834555**
Facsimile: **+44 (0)1235 835016**
E-mail: **sales@voltech.co.uk**

Voltech Instruments Inc.

11637 Kelly Road, Suite 306
Fort Myers, FL 33908
U.S.A.
Telephone: **+1 239 437 0494**
Facsimile: **+1 239 437 3841**
E-mail: **sales@voltech.com**



Note: While every care has been taken in compiling the information for this publication, Voltech Instruments cannot accept legal liability for any inaccuracies. Voltech Instruments reserves the right to alter product specifications without notice and whenever necessary to ensure optimum performance from its product range.